

# Speed2Stand

Need a bit more air?

**CasaFan**  
VENTILATOREN

**COMMERCIAL USE**  
Certified in accordance with Machinery Directive 2006/42/EC, part 1 for commercial use.



Can be adjusted to five precise settings with the optional 5-speed-transformer **ETWZ 1,0 #891020**



## Speed2Stand #304010

Chrome protective grille, fan blade in black painted aluminium, base and tubular frame in silver-grey paint.

- High-performance pedestal fan.
- Ideal for use at home and for commercial use.
- 3 speed settings which can be operated using the turn switch.
- Vertical tilt adjustable in the range of 100°.
- Chromed protective grille, housing, frame and base painted silver grey.
- Stable, anti-tip tubular frame base, height-adjustable from between 1,160 until 1,460 mm.
- Practical handle and cable winder on the reverse of the protective grille.
- High-performance aluminium fan blade, painted black.
- Degree of protection IPX0 for use in dry areas.
- 2.5 m rubber sheathed cable, H05RN-F G 3 1.0 mm<sup>2</sup> with Schuko plug.

| Product     | Code no. | Housing/grille colour | Fan blade        |
|-------------|----------|-----------------------|------------------|
| Speed2Stand | 304010   | Silver grey/chrome    | Aluminium, black |

| Technical details                          | Dimensions (mm) |
|--|-----------------|
| Power motor (W)                            | 110             |
| Voltage (V/Hz)                             | 220-240/~50     |
| Number of speeds                           | 3               |
| Rpm min. -1                                | 1,305 max.      |
| Weight (kg)                                | 12.8            |
| Sound pressure (L <sub>p</sub> -3 m) dB(A) | 40.7            |
| Sound power (L <sub>w</sub> ) dB(A)        | 62.9            |
| Airflow max. (m <sup>3</sup> /h)*          | 5,685           |
| Service value (m <sup>3</sup> /min/W)      | 1.06            |
| Fan grille Ø mm                            | 440             |
| Fan blade Ø mm                             | 400             |

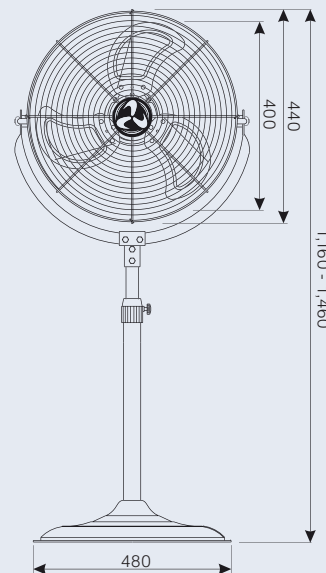

Ambient temperature - 10° to +42 °C. \* measured in accordance with IEC 60879

