

WM2 Stand Eco

Stand-alone wind machine

CasaFan
VENTILATOREN

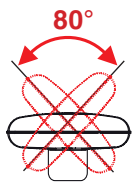

COMMERCIAL USE
Certified in accordance with Machinery Directive 2006/42/EC, part 1 for commercial use.

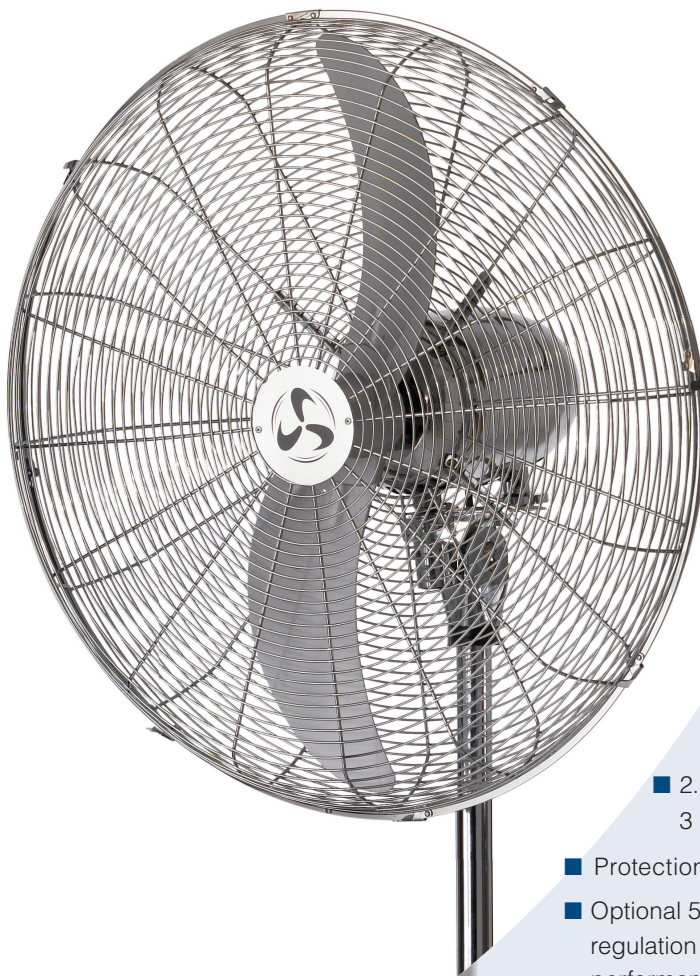

Wind machine

WM2 Stand ECO #207503

Housing, blade and stand base silver grey, protective grille and stand rod chrome

- Stand rod and protective grille chrome, housing, blade and base silver grey.
- Heavy all-metal product.
- 3 speeds selectable by rotary switch at the motor.
- Mechanical 80°-oscillation, can be switched off.
- 2-blade, sickle shaped wheel, designed for best air delivery.
- Vertical adjustable grille pitch.
- Stable, tilt-free pedestal, adjustable up to 1,580 mm with die cast base.
- 2.5 m rubber sheathed cable, H05RN-F G 3 1.0 mm² with Schuko plug.
- Protection rating IPX0 for use in dry areas.
- Optional 5-speed transformer **ETWZ 1,0 #891020** for regulation in between a whisper quiet breeze and high performance available.

Product	Code No.	Housing/blade/stand	Grille/rod colour
WM2 Stand Eco	207503	Silver grey	Chrome

Technical details	Dimensions (mm)
Power motor (W)	120
Voltage (V/Hz)	220-240/~50
Number of speeds	3
Rpm min. -1	1,190 max.
Oscillation (°)	80
Weight (kg)	16.4
Sound pressure (L _p -3 m) dB(A)	58.2
Sound power (L _w) dB(A)	76.7
Airflow max. (m ³ /h)*	9,530
Service value. (m ³ /min/W)	1.26
Grille Ø mm	700
Blade Ø mm	650

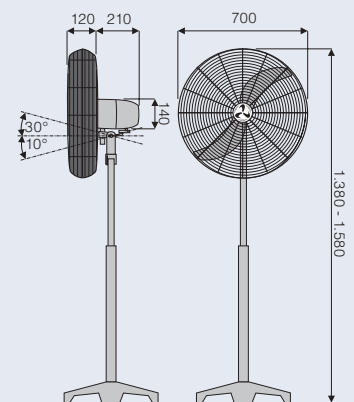

Ambient temperature - 10° to +42 °C. * measured in accordance with IEC 60879